

Solar Panel I-V Characteristic Curves

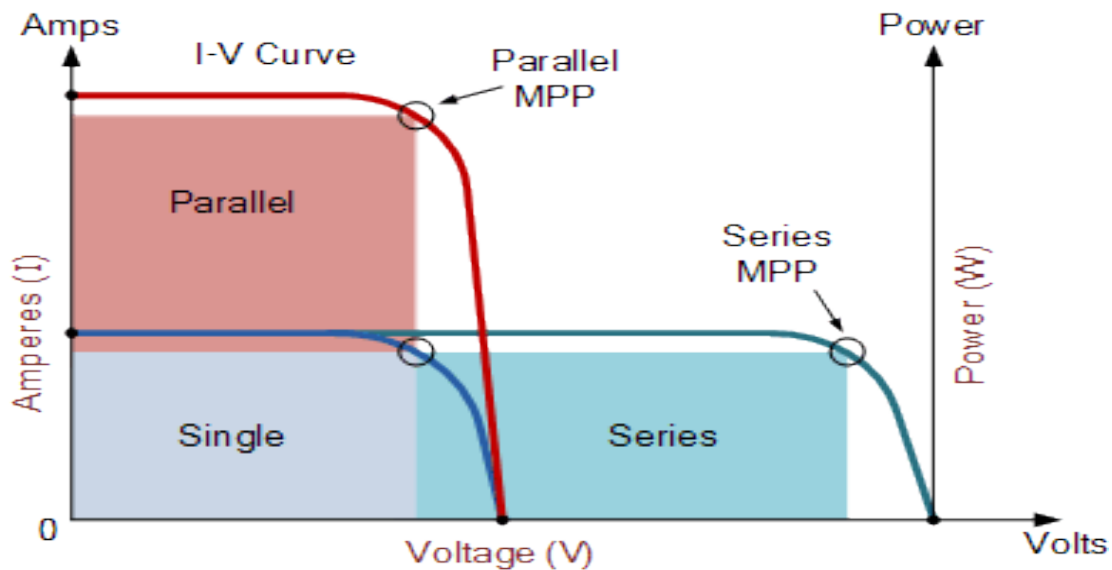

Photovoltaic panels can be wired or connected together in either series or parallel combinations, or both to increase the voltage or current capacity of the solar array. If the array panels are connected together in a series combination, then the voltage increases and if connected together in parallel then the current increases. The electrical power in Watts, generated by these different photovoltaic combinations will still be the product of the voltage times the current, ($P = V \times I$). However the solar panels are connected together, the upper right hand corner will always be the maximum power point (MPP) of the array.

There are three types of panel connection:

- 1- parallel.
- 2- series.
- 3- parallel-series connection.

- **Parallel connection:**

HOW TO SET UP YOUR SYSTEM IN PARALLEL ?

A Parallel connection is accomplished by joining the positives of two panels together, as well as the negatives of each panel together.

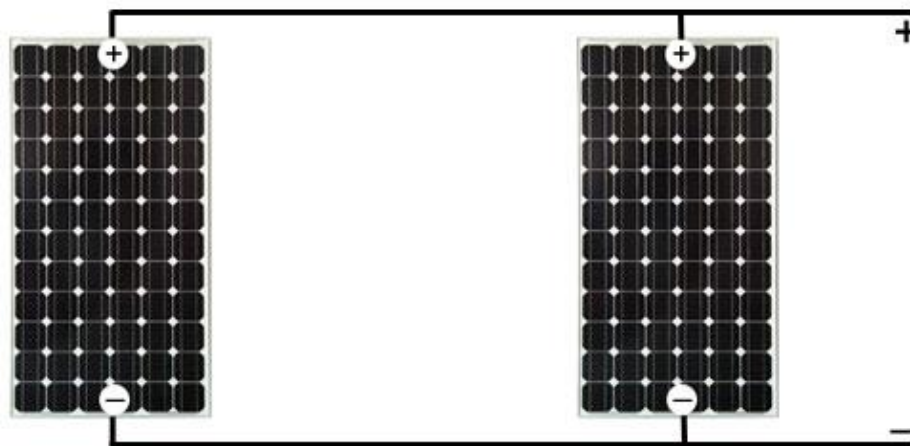

Parallel Circuit

Let's look at a numerical example. Say you have 2 x 100 Watt solar panels and a 12V battery bank. Since each panel is 12V and the battery bank you want to charge is 12V, then you need to parallel your system to keep the voltage the same. The operating voltage is 18.9V and the operating current is 5.29 amps. Paralleling the system would keep the voltage the same and increase the amps by the number of panels paralleled. In this case you have 5.29 Amps x 2 = 10.58 Amps. Voltage stays at 18.9 Volts. To check math you can do 10.58 amps x 18.9 volts = 199.96 Watts, or pretty much 200 Watts.

Advantages:

- It helps control voltage while generating the system.

Disadvantages:

- It can only be used with the same voltage values
- It can cause a high current if there are too many connections.

Problems of parallel connection:

- high amperage is difficult to travel long distances without using very thick wires so temperature will increase and the voltage and power will decrease.

Solution of problem:

The solution to this problem is to connect a series of diodes respectively to each cell to avoid or reverse reverse currents. If the voltage decreases in any series, the diodes repel the reverse currents in the faulty chain - the diode allows the current to go in one direction - and the other chains deliver the current to the desired load . One of the disadvantages of this solution is the constant loss of voltage as the diode chains reduce the output voltage because of the permanent and there is a better solution is the use of germanium diodes instead of silicon to reduce the loss of voltage.

Another solution is to use magnetic field sensors to detect reverse currents and activate the power separation switch.

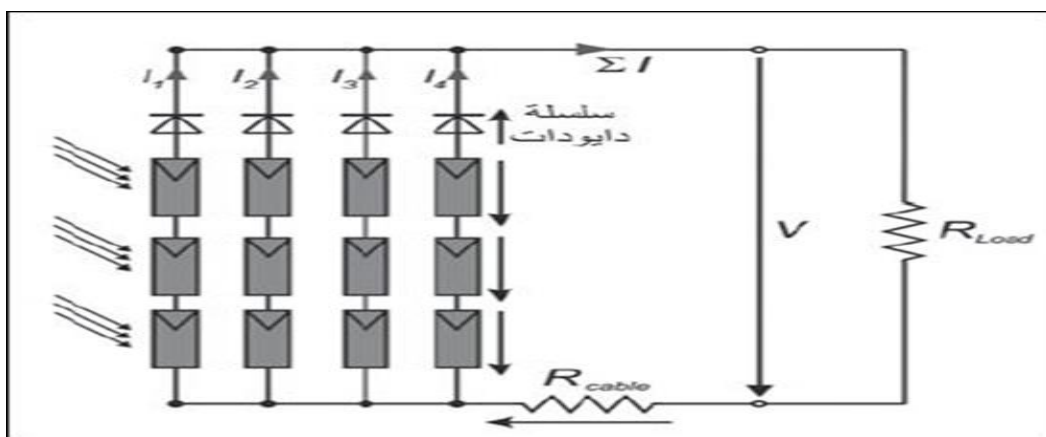

Wiring of identical ratings solar panels in parallel

When you connect solar panels in parallel, the total output voltage of the solar array is the same as the voltage of a single panel, while the total output current is a sum of the currents passing through each panel.

The latter is only valid provided that the panels connected are of the same type and power rating.

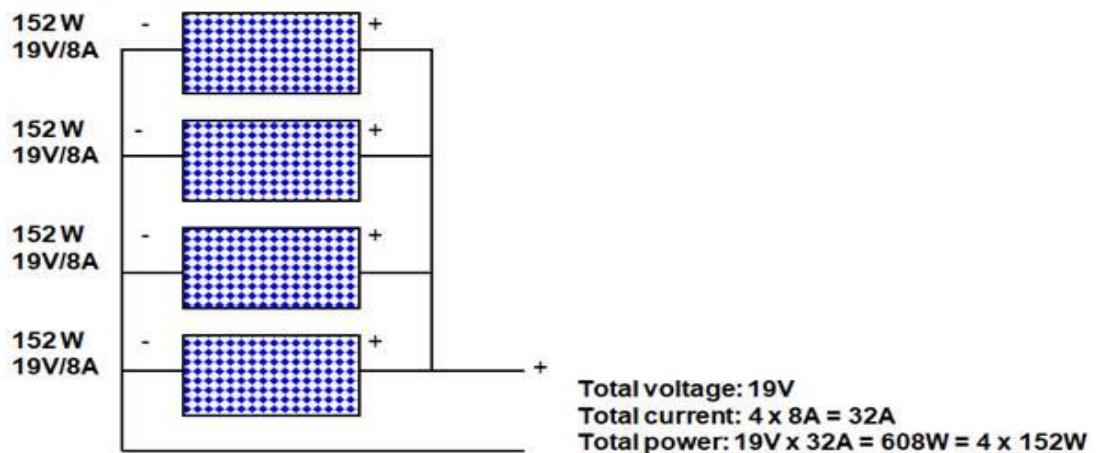

Wiring of different ratings solar panels in parallel

Example

Here is a parallel connection of solar panels of different voltage ratings and the same current rating:

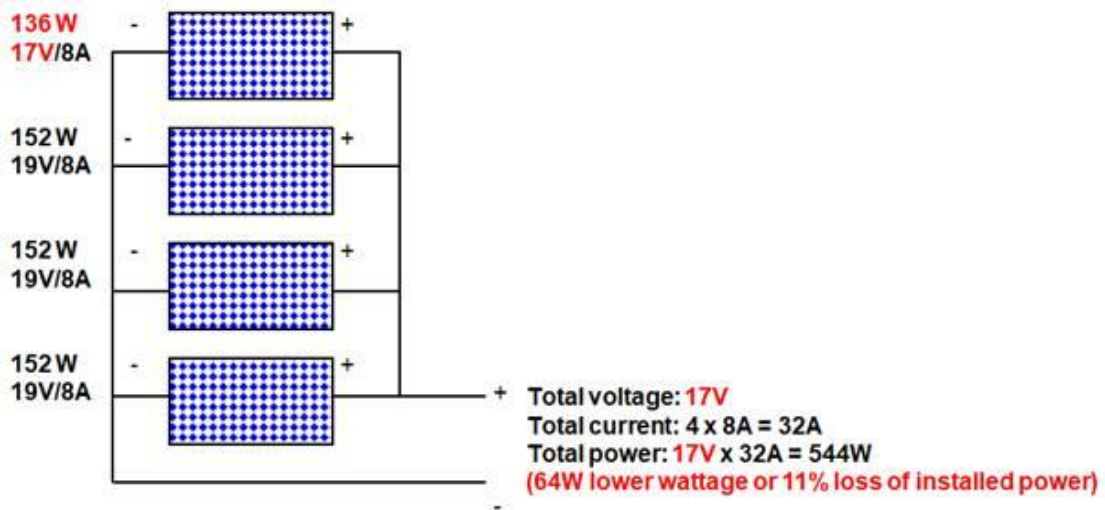

As you can see, things are getting worse, since the total voltage of the array is determined by the solar panel of the lowest voltage rating: we received 11% loss of installed solar power.

Example

Let's see what happens when we bring even more diversity and connect in parallel solar panels of different voltage and current ratings:

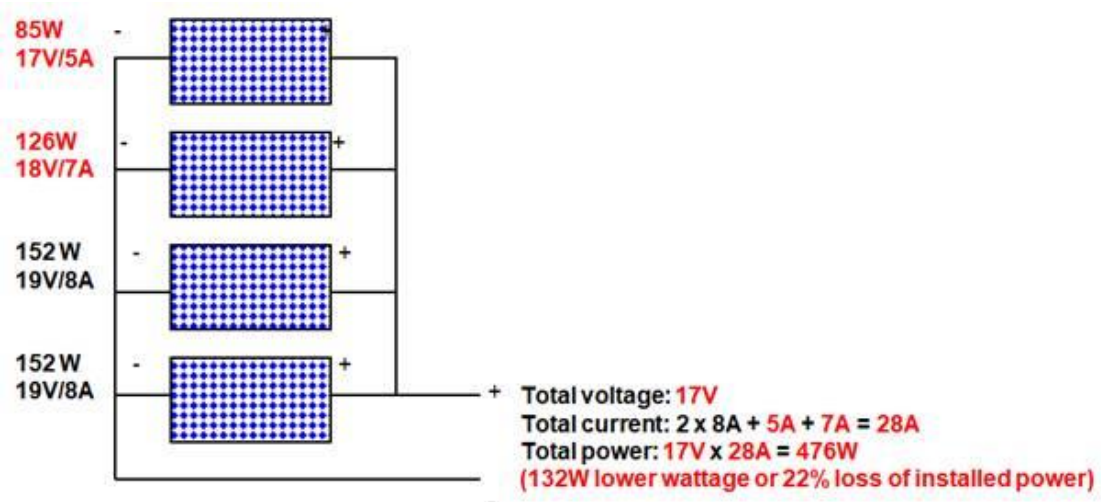

- **Series connection:**

HOW TO SET UP YOUR SYSTEM IN SERIES?

A Series connection is accomplished by joining the positive of one panel to the negative of the other panel together.

Let's look at a numerical example. Say you have 2 x 100 Watt solar panels and a 24V battery bank. Since each panel is 12V and the battery bank you want to charge is 24V, then you need to series your system to increase the voltage. in this case the 100 Watt panel has 22.5 Volts open circuit, and 5.29 amps. Connection in series would be $22.5 \text{ volts} \times 2 = 45 \text{ volts}$. Amps would stay at 5.29. The reason we use open circuit voltage is we have to account for the maximum input voltage of the charge controller.

Connecting your panels in series will increase the voltage level and keep the amperage the same

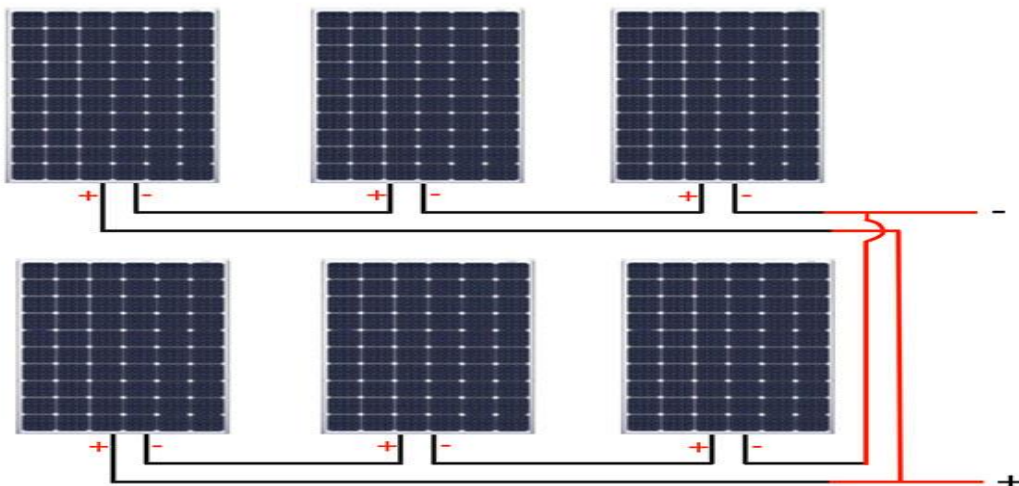

The problem of series connection:

The problem of connecting solar panels respectively is shading which may cause shaded cell damage.

In the case of local shading on the solar cell due to dust (for example, the presence of dust on a solar cell means that there is a shadow on it and thus a less radioactive radiation or less absorbent photons and therefore fewer pairs of electrons and gaps generated.

When the current of any cell is reduced by shading, a reverse voltage (ie reverse of the current of the current) occurs in the cell and this voltage may damage the cell.

Advantage :

It can control current .

The solution of shading problem:

Solving the problem of connecting the solar panels, respectively, is to connect the diodes in parallel with the direction of the solar cell to the solar cells. When the current of any cell is reduced by shading, a reverse voltage is created until this reverse voltage exceeds the diode's penetration voltage. Thus, part of the total current passes through the partial refractory diode and the remaining current completes its path through the cell.

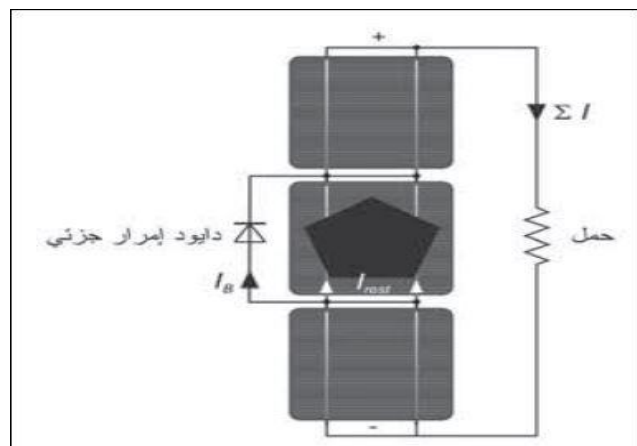

Wiring solar panels of identical ratings in series

When you connect solar panels in series, the total output current of the solar array is the same as the current passing through a single panel, while the total output voltage is a sum of the voltage drops on each solar panel.

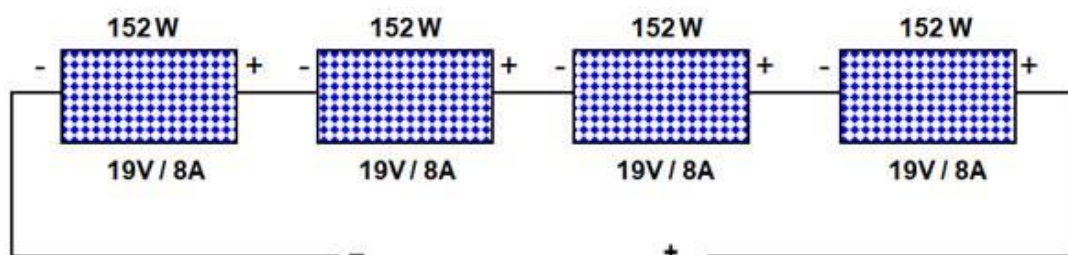

Total voltage: $4 \times 19V = 76V$
 Total current: 8A
 Total power: $76V \times 8A = 608W = 4 \times 152W$

Wiring solar panels of different ratings in series

Example

Here is a series connection of solar panels of different voltage ratings and the same current rating:

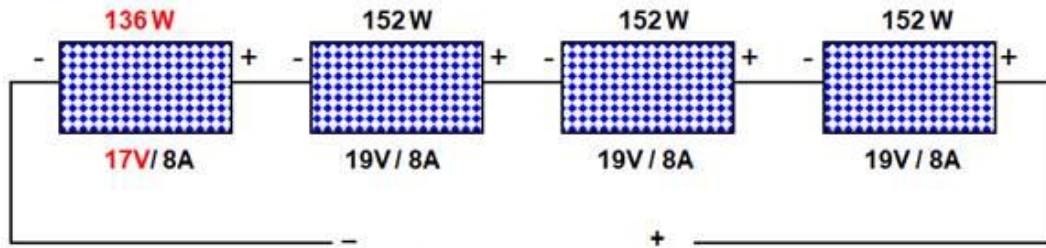

Total voltage: $3 \times 19V + 17V = 74V$

Total current: 8A

Total power: $74V \times 8A = 592W$ (16W lower wattage or 3% loss of installed power)

You can see that if one of the solar panels has a lower voltage rating (and the same current rating) compared to the remaining panels, the output power is lower than in the previous example but the loss is not significant. Things, however, are entirely different if you connect in series panels of different current ratings.

You should, however, have in mind that the current produced from a solar panel depends on the ambient temperature, solar cells temperature, and solar irradiance (we will discuss in the next topic).

Example

This time we have a series connection of solar panels of different voltage ratings and different current ratings:

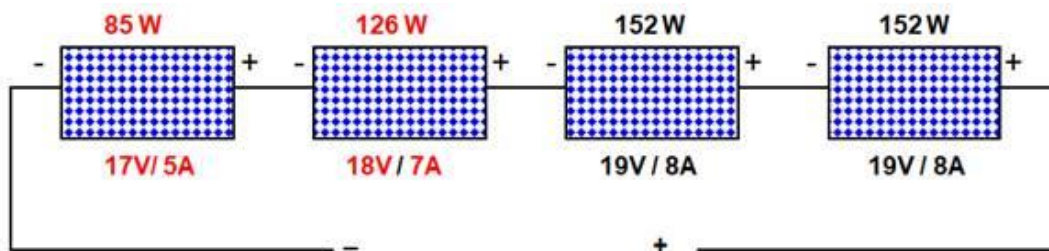

Total voltage: $2 \times 19V + 17V + 18V = 73V$

Total current: 5A

Total power: $73V \times 5A = 365W$ (243W lower wattage or 40% loss of installed power)

In this example, you can see that a total of three different types of solar panels are used.

Each panel type has its own voltage, current, and power rating.

The total current here is **determined by the panel of the lowest current rating** and, as a result, the total wattage is severely reduced (by 40%) compared to the previous example where the loss of output power is not so significant.

- *Series and parallel connection:*

HOW TO SET UP YOUR SYSTEM IN SERIES-PARALLEL?

A combination of series and parallel connection is also possible.

Indeed, this depends on the maximum possible total output voltage and maximum possible total output current of the solar array, which are limited by the maximum input voltage and the maximum input current of your charge controller (for off-grid systems) or inverter (for grid-tied systems).

Calculations show you how many panels and how to wire.

What you have to remember is that the series connection increases voltage, while the parallel connection increases current.

Both series and parallel connection result in more installed wattage, which goes down should you decide to wire solar panels of different ratings.

Example

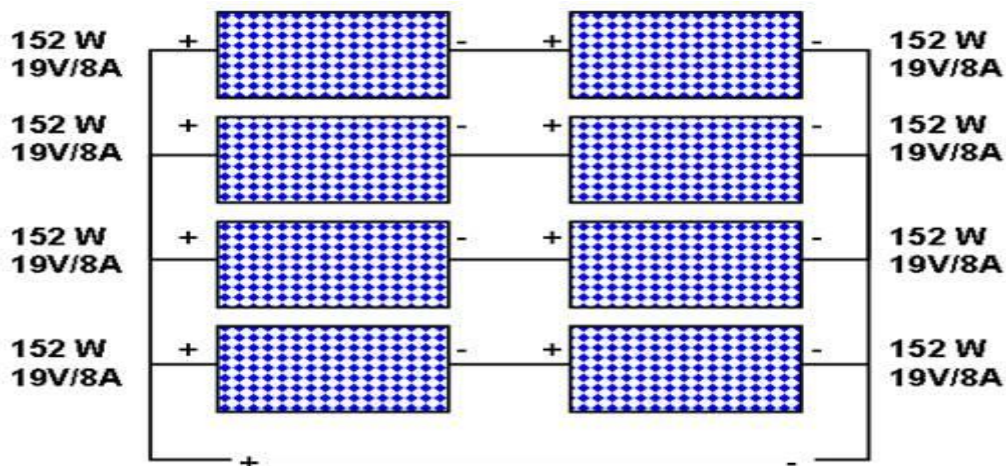

Total voltage: $19V + 19V = 38V$
Total current: $4 \times 8A = 32A$
Total power: $38V \times 32A = 1216W = 8 \times 152W$

2.6.2 Battery

For short-term to medium-term storage, the most common kind of storage in use is of course the batteries. They have just the right energy density and power density to meet the daily storage demand in the PV system. Of course, the seasonal storage problem at large scales is yet to be solved convincingly. For now, batteries still seem to be the most reliable option for PV systems in the small to medium-scale. The ease of implementation and efficiency of the batteries is still unbeatable when compared to other technologies, like pumped hydro, compressed air energy storage, conversion to hydrogen and converting back into electricity, and others.

Batteries are electrochemical devices that convert chemical energy into electrical energy. They are mainly classified as primary or secondary batteries.



Primary batteries irreversibly convert chemical energy to electrical energy. Examples include zinc carbon batteries and alkaline batteries.

Secondary batteries or as they are more commonly called - rechargeable batteries, reversibly convert chemical energy to electrical energy. That is, they can recharge when the chemical reaction is reversed using an over-potential. In other words, the excess electrical energy is stored in these secondary batteries in the form of chemical energy. Examples include lead-acid batteries and lithium-ion batteries. It is the secondary batteries that we are interested in to explore as a possible storage option. There are several kinds of secondary battery technologies available that could be used. For example, lead-acid batteries. These are the oldest and the most mature battery technology available till date.

Secondary batteries types:-

1. LEAD ACID

The common automobile batteries in which the electrodes are grids of metallic lead-containing lead oxides that change in composition during charging and discharging. The electrolyte is diluted sulfuric acid

Hint : this is the type we are going to use in our project.

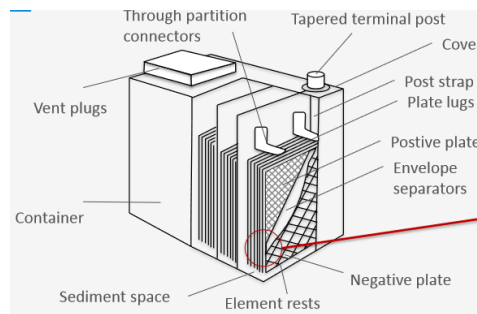

2. Lithium

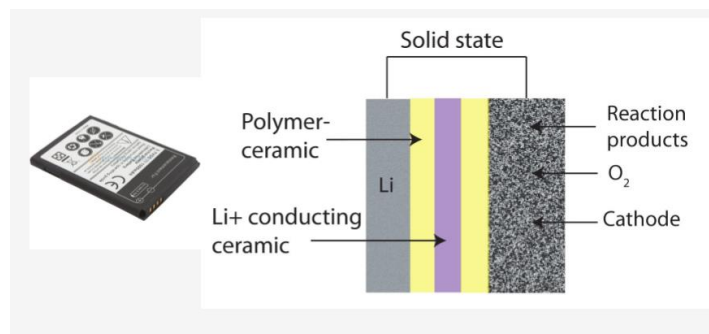

3. Nicad(nickel cadmium)

Alkaline storage batteries in which the positive active material is nickel oxide and the negative contains cadmium

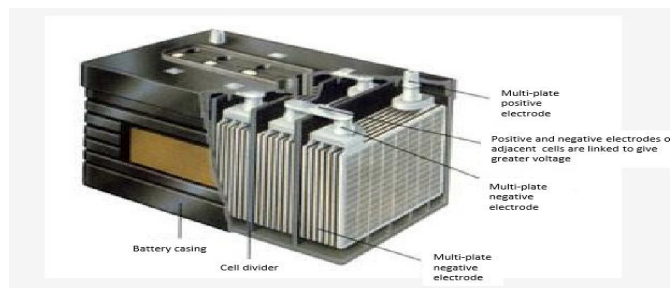

4. NIFE (NICKEL IRON)

Alkaline-type electric cells using potassium hydroxide as the electrolyte and anodes of steel wool substrate with active iron material and cathodes of nickel plated steel wool substrate with active nickel material



Basic Battery parameter:-

Rated voltage and charge capacity ratings

Every battery is rated with a certain voltage and capacity. The battery rated voltage is the nominal voltage at which the battery is supposed to operate. The so-called solar batteries or lead-acid grid plate batteries are usually rated at 12 V, 24 V or 48 V. Of course, the battery system in your PV system can attain any voltage based on the interconnection of several batteries at the system level. The term capacity in the domain of batteries refers to the amount of charge that the battery can deliver at the rated voltage. The capacity is directly proportional to the amount of electrode material in the battery. This explains why a small cell has lesser capacity than a large cell based on the same chemistry, even though the open-circuit voltage across the cell will be the same for both the cells. Thus, the voltage of the cell is more chemistry based, while the capacity is more based on the quantity of the active materials used.

The unit for measuring the battery capacity is ampere-hour or amp-hour, denoted as Ah. It's good to recollect from high school physics, that amount of charge is usually measured in Coulombs.

As the electric current is defined as the rate of flow of electric charge, the charge can also be equivalently measured in ampere-hour. But we will stick to the more convenient unit of amp-hours for measuring the battery capacity. I'll shortly explain the reason for this. We must not confuse the battery capacity with the energy capacity.

Energy capacity

We must not confuse the battery capacity with the energy capacity. Energy capacity of the battery or any storage device for that matter is the total amount of energy that the device can store. This is usually measured in watt-hours.

How do we calculate the energy capacity of the battery, knowing the voltage and the battery capacity?

the total battery energy capacity in watt-hours = Rated battery voltage in volts x Battery capacity in amp-hours

You must be wondering what is the significance of amp-hours as the unit of battery capacity? The unit itself gives us some important clues about the battery properties.

If we take a brand new battery with a 10 amp-hour capacity, it can theoretically deliver a 1 A current for 10 hours at room temperature.

$$\frac{10Ah}{1A} = 10h$$

C- Rate

Let's first understand how the battery charges and discharges. As known, the charging and discharging of the battery at the cell level is just the right kind of chemical reaction taking place. At an electric level, charging and discharging depend on the direction of current into and from the battery respectively.

How does this relate to the battery capacity?

This is where the C-rate comes in. C-rate is a measure of the rate of discharge of the battery relative to its capacity. The C-rate 'number' is nothing but the multiple of the current over the discharge current that the battery can sustain over one hour.

For example, a C-rate of 1C for 10 Ah capacity battery would correspond to a discharge current of 10 A over 1 hour.

On the other hand, a C-rate of 2C for the same battery would correspond to a discharge current of 20 A over half an hour.

Similarly, a C-rate of 0.5C implies a discharge current of 5 A over 2 hours.

In general, it can be said that a C-rate of n-C corresponds to the battery getting fully discharge in time t.

$$t = \frac{1}{C - rate}$$

In general, a higher or lower C-rate will depend on the charging and discharging current that the battery with a certain capacity experiences.

Efficiency of storage

like every other component in the PV system, the efficiency of the storage system is also of high importance.

$$\eta = \frac{E_{out}}{E_{in}}$$

In simple terms: It is the ratio of total storage system input to the total storage system output.

For example if 10 kWh is pumped into the storage system while charging, and you can effectively retrieve only 8 kWh while discharging, then the round trip efficiency of the storage system is 80%. The round trip efficiency, in case of the batteries, can be broken down and studied further.

The batteries are reported to have two kinds of efficiencies:

voltai efficiency: It is the ratio of the average discharging voltage to the average charging voltage.

$$\eta_v = \frac{V_{discharging}}{V_{charging}}$$

This stems from the fact that the charging voltage is always a little above the rated voltage so as to drive the reverse chemical reaction in the battery.

the coulombic efficiency: This is defined as the ratio of the total charge out of the battery to the total charge into the battery over a full charge cycle.

$$\eta_c = \frac{Q_{discharging}}{Q_{charging}}$$

Battery efficiency is defined as the product of these two efficiencies. This overall battery efficiency can be seen as the round trip storage efficiency that is usually considered while comparing different storage devices. This battery efficiency includes the effects of all the chemical and electrical non-idealities occurring in the battery.

$$\eta_{batt} = \eta_c \eta_v$$

State of charge and depth of discharge

the state of charge or the SOC. This is defined as the percentage of the battery capacity available for discharge.

$$SOC = \frac{E_{available}}{C_{batt}V}$$

Thus a 10 Ah rated battery that has been drained by 2 Ah is said to have a SOC of 80%.

Depth of discharge is defined as the percentage of the battery capacity that has been discharged.

$$DOD = \frac{E_{discharge}}{C_{batt}V}$$

Thus, a 10 Ah battery that has been drained by 2 Ah has a depth of discharge of 20%. Thus the DOD and SOC can be seen as complimentary to each other.

Cycle life

Cycle lifetime is defined as the number of charging and discharging cycles after which the battery capacity drops below 80% of the nominal value. Usually the cycle life is specified as an absolute number. But it would be a gross generalization to say that the battery lifetime can be stated as a single number, without any other specifications. Why? It's because the various battery parameters discussed so far are related not only to each other but are also dependent on temperature.

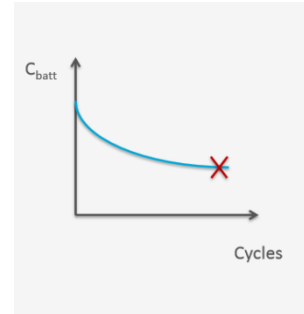

Let us discuss this interesting interplay of the battery parameters. Now, the cycle life depends heavily on the depth of discharge until which those charge cycles last. Also, it depends on temperature. This can be seen in the graph shown here for a typical maintenance free lead-acid solar battery.

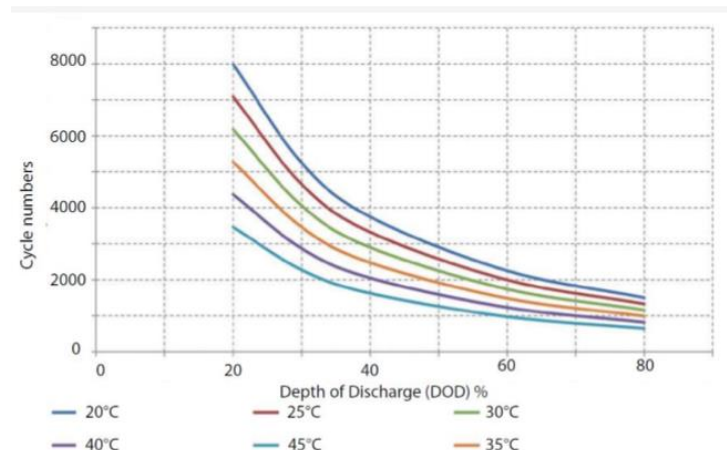

Clearly, the battery lasts longer under colder temperatures of operation. Furthermore, for a particular temperature, cycle lifetime depends non-linearly on the depth of discharge or DOD. The smaller the DOD, the higher the cycle life. However, such a higher cycle life would also mean that those additional cycles you gain can only help you for a smaller depth of discharge. Thus, it could be said that the battery will last longer if the average DOD could be reduced over its normal operation. Also, battery overheating should be strictly controlled. Overheating could occur due to overcharging and subsequent overvoltage of the lead-acid battery.

2.6.3 Charge controller



Victron Blue Solar MPPT Charge Controller



Steca Solarix MPPT Charge Controller

What is a charge controller, and why do we need it?

Note that the use of charge controllers is found in PV systems with battery usage. In most cases, this would mean a stand-alone PV system.

We have learnt the importance of having the right amount of current and voltage being provided to the battery. You know that the battery is an electrochemical device which requires a small over-potential when it needs to charge. However, battery technologies have strict voltage limits required for their optimal functioning. Also, the amount of current sent to the battery by the PV array and the current being discharged away by the load have to be within required limits for proper functioning of the battery. You have also seen previously, how a lead-acid battery responds poorly to overcharge and over-discharge

Under such circumstances, a direct coupling between a PV array, battery and load is far from healthy for the battery.

This means that we need a device that can interface 3 way - between the PV system, the battery and the load, and ensure that the electrical parameters around the battery are maintained within the battery manufacturer's specifications. This is where the charge controller comes in. The modern charge controller performs a multitude of functions. These functions can further be enhanced depending on the set of technologies the manufacturer wishes to integrate within the device.

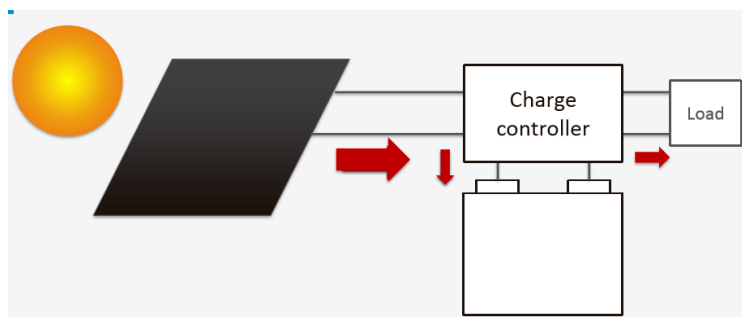

When the sun is shining in peak summer, there is enough PV energy meeting the load. The excess energy is sent to the battery. But when the battery is fully charged, and the PV array is still connected to the battery, the battery tends to overcharge. This brings about its own set of problems like gas formation in the lead-acid battery,

capacity loss and overheating, to name a few. The charge controller here plays a vital role by cutting off the PV power from overcharging the battery. Similarly, in severe winters when low irradiance causes the load demand to be more than the supply power, the battery is heavily drawn. The battery under such conditions tends to be over-discharged, which weighs strongly on the battery life, as discussed in the previous block. The charge controller under such a case prevents overdischarge by disconnecting the battery from the load. For optimal performance, the battery voltage has to be within specified limits. The charge controller can help in maintaining an allowed voltage range so as to ensure a healthy operation. Also, the PV array could have its V_{mpp} at different levels, based on the temperature and irradiance conditions.

Therefore the charge controller needs to do an appropriate voltage regulation to ensure the battery operates in the specified voltage range, while the PV array functions at MPP. This means that the modern charge controller can, and often does, integrate an MPP tracker within its design.

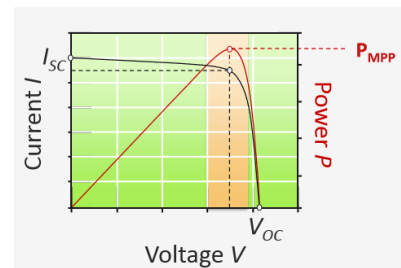

We have seen before how the battery has certain C-rates defined. Higher the charge/discharge rates, the lower the coulombic efficiency of the battery will be. The optimal charge rates indicated by the manufacturer could be adhered to by manipulating the current flowing into the battery. With proper current regulation, the charge controller is also able to control the C-rates. At the very least, the charge controller can impose the limits on the maximum allowable currents flowing into and from the battery. Without blocking diodes, it is even possible that when the PV array is producing a very low voltage, the battery can load the PV array, or in other words, the battery can try to forward bias the PV modules and make them consume the battery power.

Traditionally, blocking diodes are used at the PV panel or string level to prevent the supposed "back discharge" of the battery through the PV array. This function is also easily integrated these days via the charge controller.

I won't go into too much of the hardware details but most charge controllers usually have either a shunt (boost) or a series(buck) kind of controller.

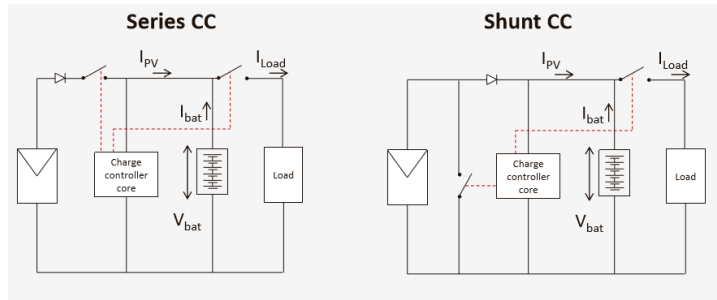

2.6.4 Solar Inverter

Inverter is a device that is used to convert DC voltage coming of batteries or PV solar cells into AC voltage.

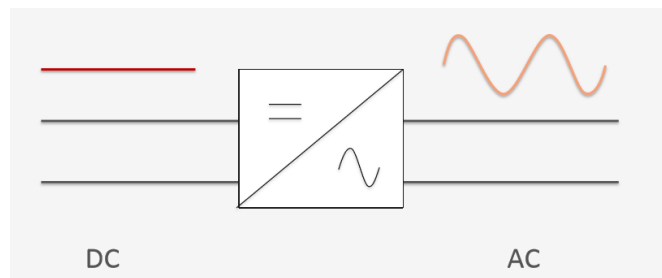

Given the time constraints, we will not go into the internal circuitry of the inverter. But we will talk about the features of the solar inverter and its application in the modern PV system. Now inverters could be classified based on their size, mode of operation, or implementation topology. Here I will talk about the classification based on the mode of operation; under this the inverters can be classified into 3 broad categories: stand-alone inverters, grid-connected inverters and bimodal inverters.

stand-alone inverters

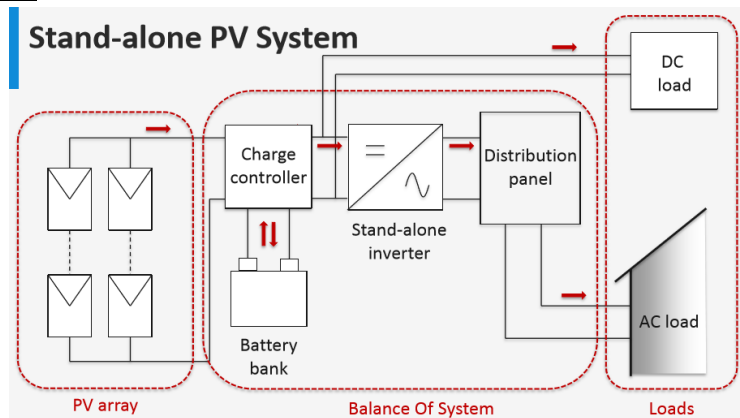

In this case, the PV system is stand-alone, the load can only depend on the PV system for power. So the inverter that supplies AC power to the load has to appear as a voltage source with a stable voltage and frequency, supplying power at 230 V_{AC} or 110 V_{AC} or as is the voltage standard at the location.

grid-connected inverters

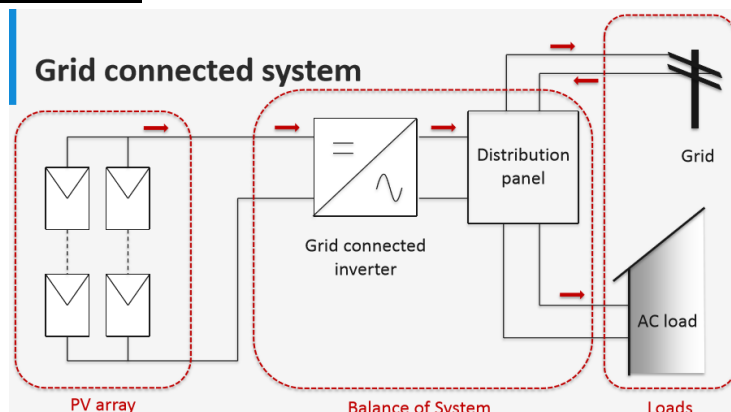

In this case, the PV system is grid-connected; the load can depend on the PV system as well as the grid for power. There is an exchange of power between the grid, the inverter and the load. The inverter latches onto the grid frequency and voltage. The inverter's main task is to only pump power into the grid. So the inverter that supplies AC power to the grid as a current source, while the role of the constant voltage source in the system is fulfilled by the grid.

Hybrid PV system inverters

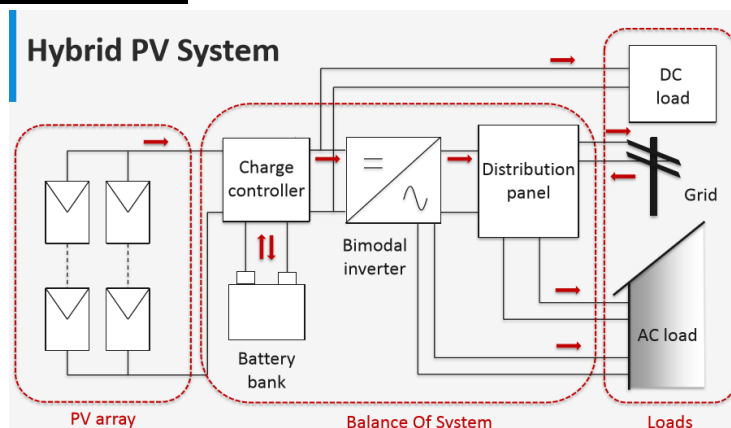

These configurations are much rarer. The PV system is capable of functioning either as a stand-alone system with battery storage or as a grid-connected mode. The inverter plays a crucial role, as it has the necessary hardware implementation to work in either mode, based on the operating conditions.

In the stand-alone mode, the grid is disconnected, and the system might cater to some special backup loads with the inverter behaving as an AC voltage source.

In the grid-connected mode, the inverter behaves as an AC current source. These bimodal inverters are usually more expensive, and are used less often.

There can be 4 different categories under this classification

- Central inverters, which are usually around several kW to 100 MW range.
- Module inverters or micro inverters, typically rated around 50 to 500 W.
- String inverters, typically rated around 500 W to a few kW. A string is nothing but a number of PV modules connected in series.
- multi-string inverters, typically rated around 1 kW to 10 kW range.

Central inverters

This is the most traditional inverter topology in use. As seen in the figure this is a simple implementation with one central inverter catering to all the PV modules in a PV system.

Hint : this is the type we are going to use in our project.

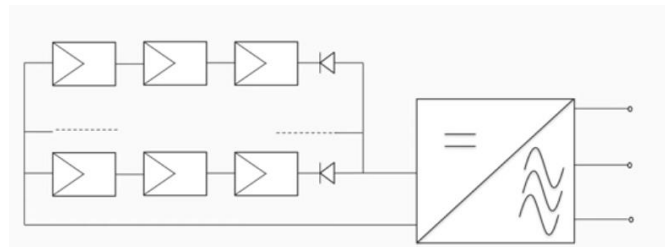

While this inverter topology increases the ease of system design and implementation, it suffers from several drawbacks:

- In large systems, large amounts of DC power will be transferred over long cables to reach the central inverter.
- This increases DC wiring costs, and also decreases safety, as DC fault currents are difficult to interrupt.
- An MPPT implementation inside the central inverter will only cater to the entire system as a whole.
- If the various modules, strings are mismatched, let's say due to partial shading, the overall system output is drastically reduced.
- Also, the system is usually designed for a fixed power.
- There is little scope for extendibility of the system if more strings and modules need to be added.

Micro inverters

let's look at the micro inverters or module level inverters.

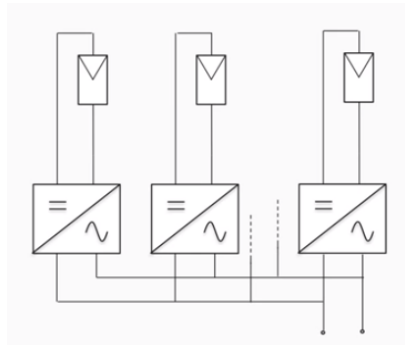

As the name suggests, each module has a dedicated inverter with an MPP tracker. Therefore the topology is more resilient to partial shading effects as compared to the central inverter topology. Clearly, the micro inverters provide the highest system flexibility, since extending the size of a system under this topology is far simpler. Furthermore, the DC wiring costs are greatly reduced. However, the investment and maintenance costs tend to increase, especially if the cost per Wp are compared.

String inverters

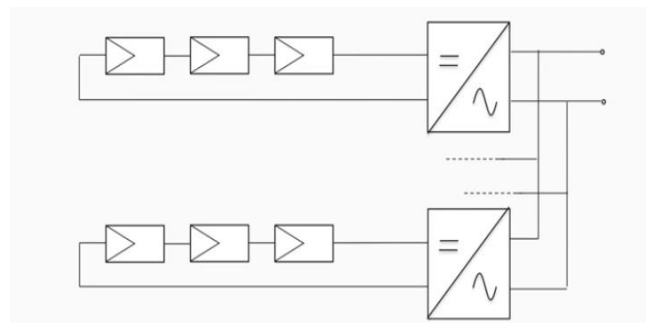

Then we have the string inverter concept, which seeks to strike a balance between the module level inverter and the central inverter topologies. The string inverter topology is more resilient to mismatch than the central inverter, because each string is independently operated at its MPP, thus guaranteeing a higher energy yield. String inverters are smaller than central inverters. However, the implementation is more complex than the module inverter. Also, the partial shading will have a greater influence over the string inverter topology

Multi-String inverters

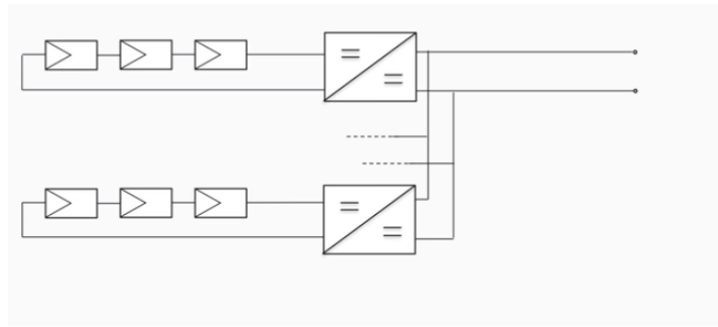

This concept seeks to combine the higher energy yield of a string inverter with the lower costs of the central inverter. Each of the strings is pre-power-processed using low power DC-DC converters. Each string has its own MPP tracker implemented alongside the DC-DC converter. All the converters are connected via a DC bus to the inverter, and ultimately to the grid. Within a certain power range, only a new string with a dedicated DC-DC converter has to be included to expand the system size.

We now have an overview about the solar inverters and their topologies. Of course, the choice of your topology for implementation would depend entirely on the system needs, size, and your system's budget. But in general, while choosing an inverter for your PV system, what are the requirements from a good solar inverter?

There are several characteristics expected from a good solar inverter.

- 1- The inverter must be more efficient. Typical efficiencies are in the range of more than 95% at rated conditions.
- 2- Thus inverters are expected to have very low harmonic content on the line currents.
- 3- Islanding refers to the situation in which the inverters in a grid-tied setup continue to power the system even though the power from the grid operator has been restricted. Due to safety issues, islanding needs to be prevented.
- 4- Depending on the topology, it is expected that the inverters have in-built MPP trackers.