

Assignments

Modeling Flight Dynamics with Tensors

Lecture 4

Problem1 Rotation Tensors

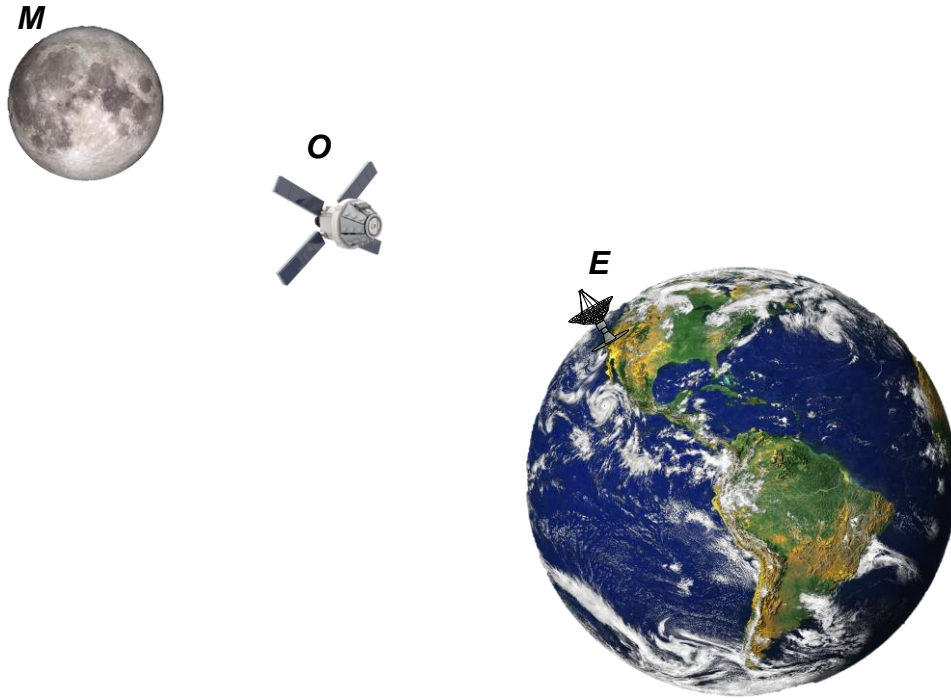

To land the Orion on the Moon it will be oriented by the radar signals from Vandenberg. Known are the relative orientations given by rotation tensors \mathbf{R}^{ME} and \mathbf{R}^{OE} . Express the orientation of the Orion wrt the moon in terms of the rotation tensor \mathbf{R}^{OM} .

Problem 2 Rotation Vector

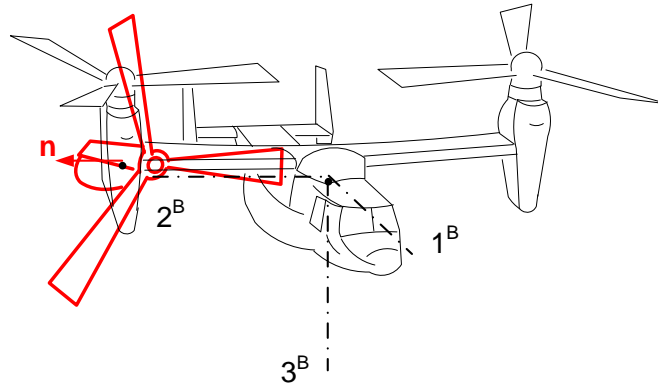

The Osprey rotates its propellers from vertical take-off to horizontal flight through 90 deg . The

rotation tensor of the right propeller is in body coordinates $[R_{90}]^B = \begin{bmatrix} 0 & 0 & 1 \\ 0 & 1 & 0 \\ -1 & 0 & 0 \end{bmatrix}$. Determine

the unit rotation vector $[n]^B$ using the equations of Slide 9.

Problem 3 180° Rotation Tensor

Use the general rotation tensor equation of Slide 7 and derive the tensor \mathbf{R}_{180} for a 180° rotation. You also can get it by multiplying \mathbf{R}_{90} with itself $\mathbf{R}_{180} = \mathbf{R}_{90}\mathbf{R}_{90}$. To demonstrate that this is true use a general unit rotation vector \mathbf{n} for your \mathbf{R}_{180} relationship and the \mathbf{R}_{90} , and show that they both lead to the same numerical result.